KIT PART NUMBER 7212196
INSTRUCTIONS FOR INSTALLING A LOCK COVER ON AN OUTDOOR
SNACK ATV MERCHANDISER

CHECK THE PARTS RECEIVED IN THE KIT WITH THE PARTS LIST IN THESE INSTRUCTIONS. IF ANY PARTS ARE MISSING, CONTACT THE NATIONAL VENDORS PARTS DEPARTMENT IMMEDIATELY.

Read these instructions carefully before installing the kit.
Keep these instructions for part numbers and for future reference.

This kit contains the following :

PART NUMBER	DESCRIPTION	QUANTITY
7212184	WELD ASSEMBLY - SIDE LOCK GUARD	1
7212209	LOCK ASSEMBLY - MILLENNIA LOCK GUARD	1
1211105	NUT - 1/4 - 20 W/LOCKWASHER	2
1211112	TRAY BOLT	2

Tools Required:

- Common screwdriver
- Nutdriver set
- Ratchet wrench with sockets
- Drill
- 9/32" Drill bit

Approximate Time Required: 30 minutes.

1. Remove the change cup by removing the four (4) screws and cup spacers from the back of the main door (see figure 1). Remove the change cup door.
2. Remove filler assembly by removing the two nuts from the back of the main door (see figure 1).
3. Remove the lower right trim panel by removing the screws from the back of the main door that retain it, approximately twelve (12) screws (see figure 1).
4. Remove the lock assembly by removing the two (2) carriage bolts, nuts, and washers that retain it from the back of the main door (see figure 1). Remove the lock cylinder from the lock assembly and keep it for later use.

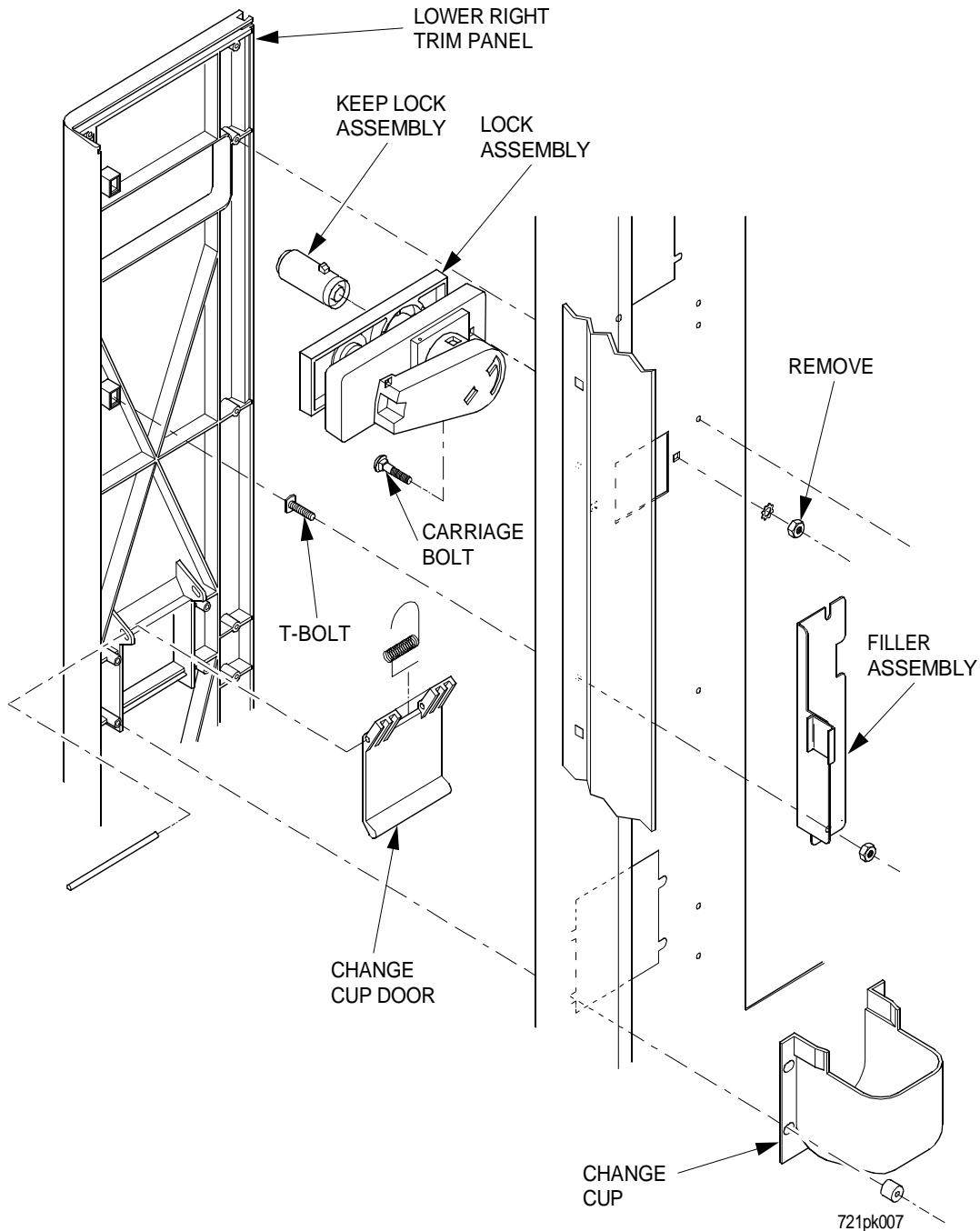

Figure 1

5. Push locking actuator and lock handle base on the new lock assembly provided through the rectangular hole in the trim piece that was removed (see figure 2, detail A).
6. Rotate the locking actuator and lock handle to their normal orientation.
7. Push the actuator on new lock assembly provided through the hole in the main door and align it with the drive pin in the locking bar. Position the back of the lock base into the hole in the main door for assembly (see figure 2, detail B).

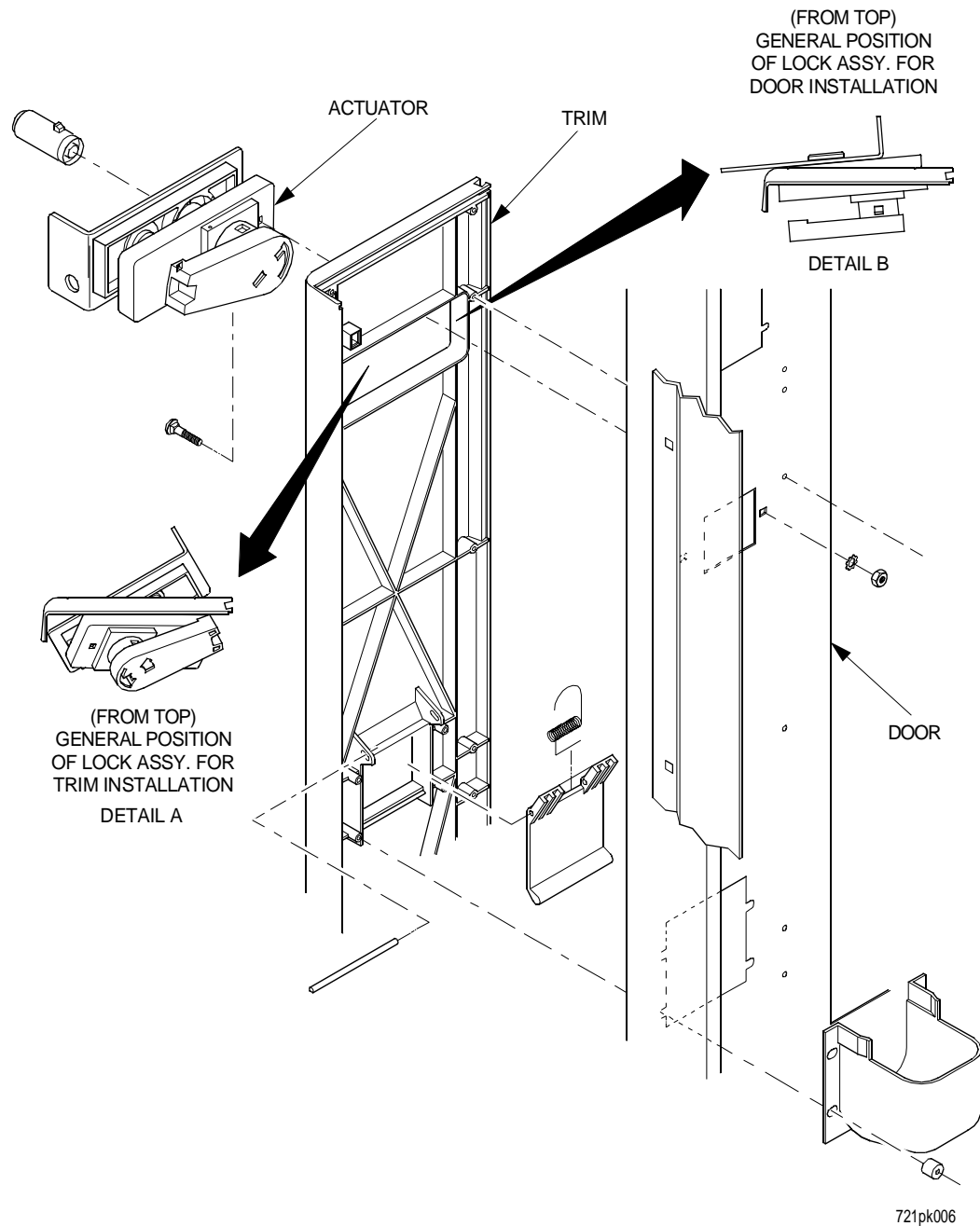

Figure 2

8. Attach the lock assembly to the main door with the two (2) carriage bolts removed previously.
9. Attach the trim piece removed with the screws removed previously.
10. Attach the filler assembly with the nuts removed previously.

11. Attach the change cup and the change cup door removed previously.
12. Close main door and lock securely with your standard lock cylinder.
13. Position lock cover horizontally and hold side support weldment in position tightly against the bend in the vandal panel (see figure 3). Mark the center of the two square holes on the door vandal panel.
14. Drill two holes through the vandal panel and door as marked to accept a 0.25" diameter bolt.
15. Attach the side support weldment with the two (2) carriage bolts, nuts, and washers provided (see figure 3).

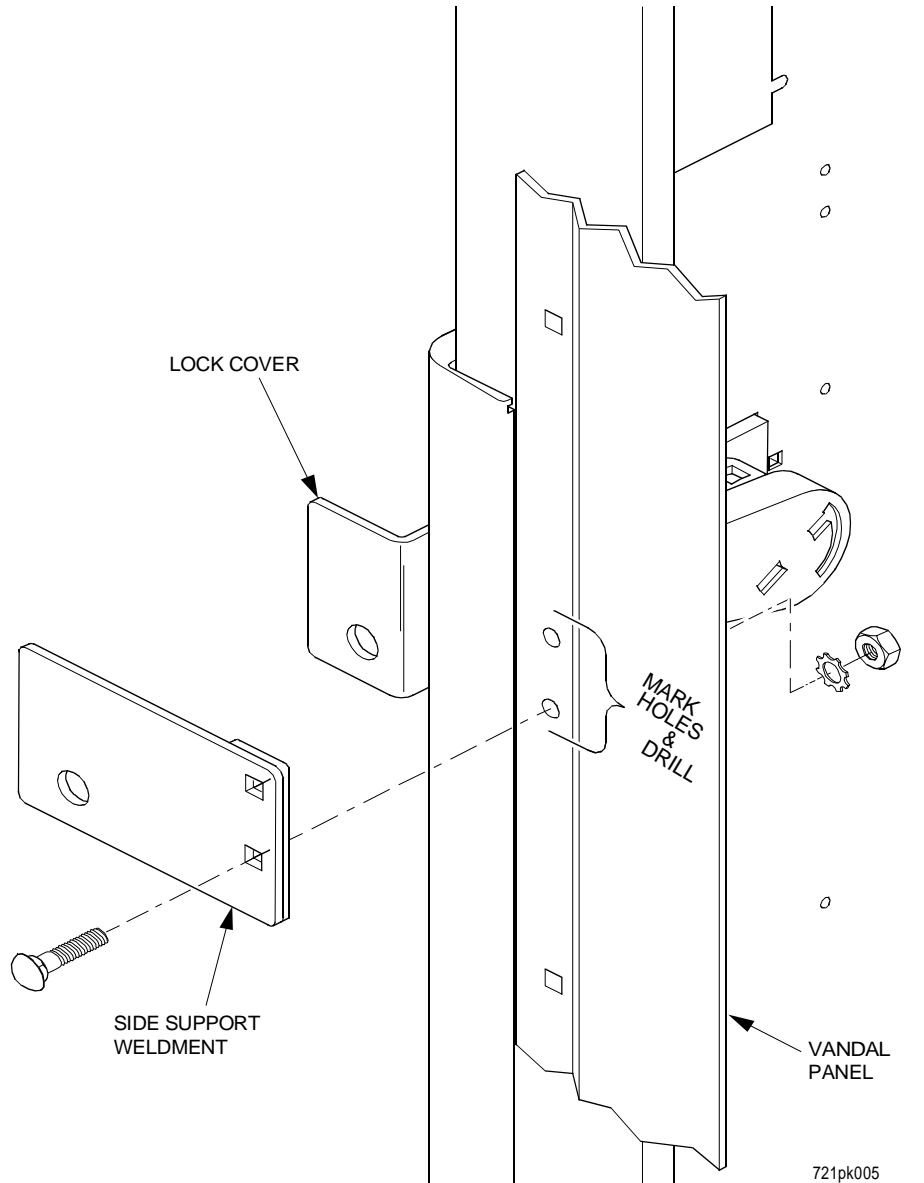

Figure 3